



[I-21/340/2024-W&M Section]
GOVERNMENT OF INDIA/भारत सरकार
MINISTRY OF CONSUMER AFFAIRS, FOOD AND PUBLIC DISTRIBUTION
उपभोक्ता मामले, खाद्य एवं सार्वजनिक वितरण मंत्रालय
DEPARTMENT OF CONSUMER AFFAIRS/ उपभोक्ता मामले विभाग
LEGAL METROLOGY DIVISION/ विधिक मापविज्ञान प्रभाग

Krishi Bhawan/कृषि भवन, नई दिल्ली
Dated/दिनांक 04.02.2025

Certificate of Approval of Model/ मॉडल का अनुमोदन प्रमाणपत्र

Whereas the Central Government, after considering the report submitted to it by the prescribed authority, is satisfied that the model described in the said report is in conformity with the provisions of the Legal Metrology Act, 2009 (1 of 2010) and the Legal Metrology (Approval of Models) Rules, 2011 and the said model is likely to maintain its accuracy over periods of sustained use and to render accurate service under varied conditions;

Now, therefore, in exercise of the powers conferred by section 22 of the Legal Metrology Act, 2009 (1 of 2010) read with sub-rule (6) of rule 8 and sub-rule (4) of rule 11 of the Legal Metrology (Approval of Models) Rules, 2011, as per Schedule Seventh of the Legal Metrology (General) Rules, 2011, the Central Government hereby issues the certificate of approval of the model of non-automatic weighing instrument with digital indication of High accuracy (Accuracy class-III) of series "MP72X2 Multi Interval" and with brand name "ZEBRA" (hereinafter referred to as the said model), manufactured by M/s. Zebra Technologies Corporation, 3 Overlook Point, Lincolnshire, IL 60069, USA, and imported and marketed in India without any alteration before or after sale by M/s. MARKSS INFOTECH LIMITED, 70 B, Kandivali Indl. Estate, M.G.Road, Charkop Kandivali, Mumbai Suburban, Maharashtra - 400 067 and which is assigned the approval mark IND/09/25/ 6 (the picture of model is given below as figure 1.);

The said model is a strain gauge type load cell based non-automatic weighing instrument with a maximum capacity of 15kg and minimum capacity of 40g. The verification scale interval (e) is 2g up to 6kg, above 6kg and up to 15 kg is 5g . It has subtractive tare. The liquid crystal display (LCD) indicates the weighing result. The instrument operates on 230Volts, 50Hertz alternating current power supply. It is used as Table Top type weighing instrument.

Figure 1

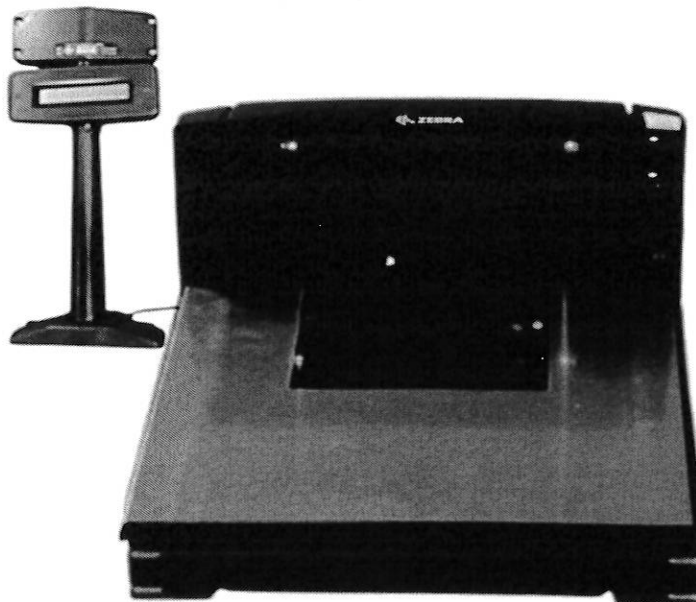

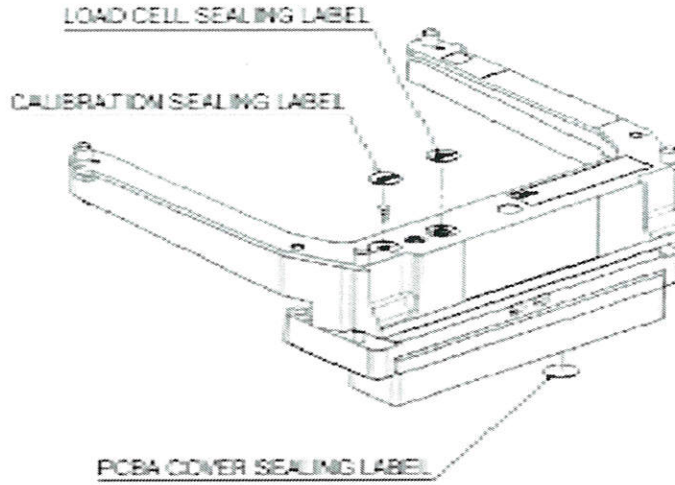

Figure 2

Sealing is done by passing the sealing wire through the holes provided on the body of machine. A lead seal is put at the end of the wire for stamping purpose (a typical schematic diagram of sealing provision to prevent the fraudulent practices of the model is given above as Figure 2). A dip switch has also been provided in mother board to disable access to external calibration.

[F.No. I-21/340/2024-W&M Section]

Ashutosh Agarwal

(Ashutosh Agarwal/आशुतोष अग्रवाल)

Director (Legal Metrology) to Govt. of India/ निदेशक (विधिक माप विज्ञान) भारत सरकार

Phone/दूरभाष 01123389489

Email/ई-मेल: dirwm-ca@nic.in

Online Application No. 20939